

**HEAT AND CONTROL**<sup>®</sup>

# Paragon Sheeter

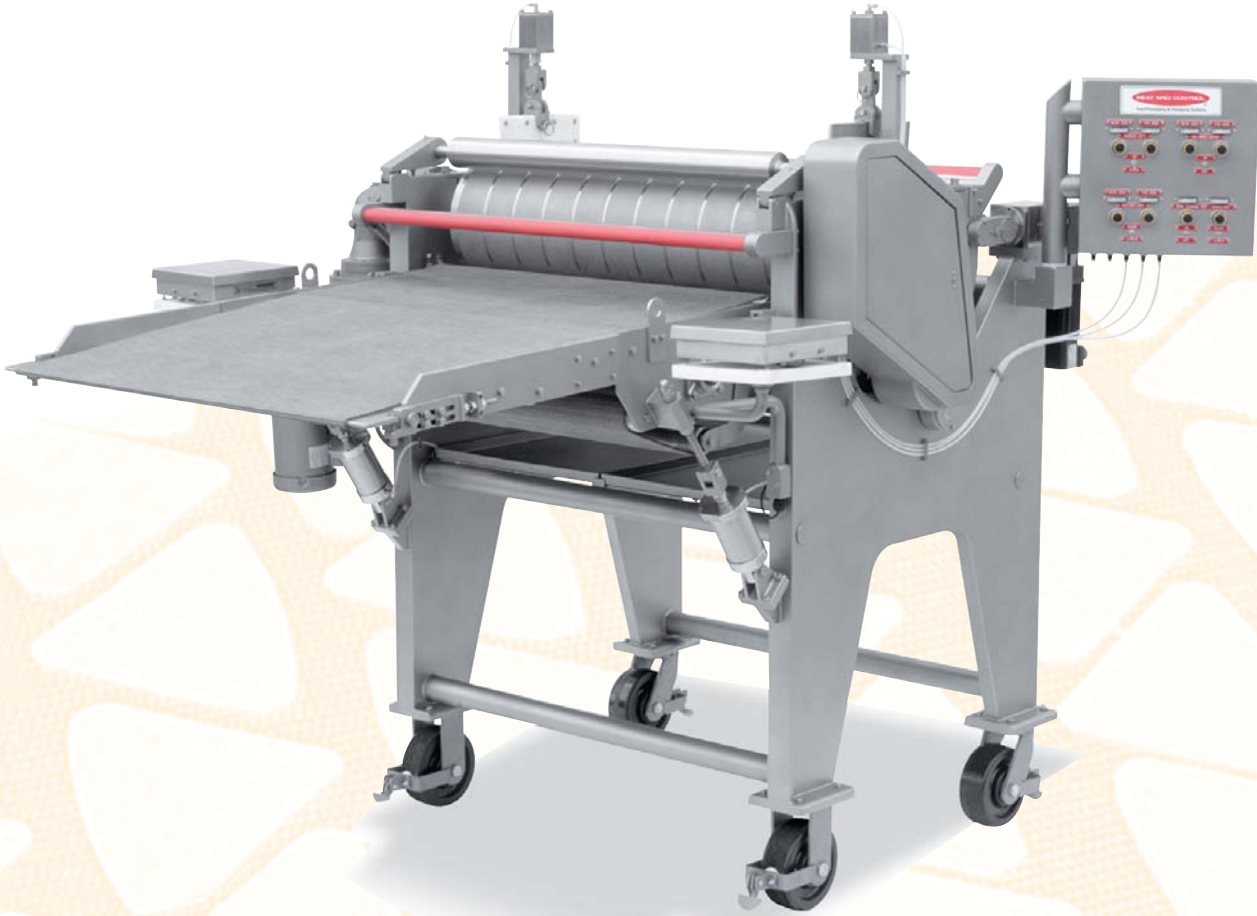

*Sheet the most uniform  
chips, tortillas, tostadas  
and taco shells!*

**HEAT AND CONTROL**

®

## Paragon Sheeter

Produce the most uniform product with the world's most advanced sheeter.

### Heavy-duty precision

Consistently uniform product piece weight is assured by Paragon's ultra rugged construction. The unique hinged rear roll design maintains precise gap control over years of service. Differential speed rolls eliminate the rear stripping wire. Optional digital linear encoders display the roll gap for fast, accurate set-up.

### Simple service

Direct drives eliminate the maintenance of drive chains and sprockets. Rolls and drives can be removed as a single assembly in minutes.

### Easy cleaning

Open frame design and washdown construction reduce the time and cost of sanitation.

## Automatic Piece Weight Control

Variations in masa moisture and density make sheet thickness a poor measure of piece weight. So Paragon's optional Automatic Weight Control system uses actual piece weight measurements to deliver continuously uniform product. Periodically place a product sample on the sheeter's scale and the roll gap adjusts itself to maintain the programmed target weight. Settings for different products can be stored in Paragon's PLC touch screen control system.

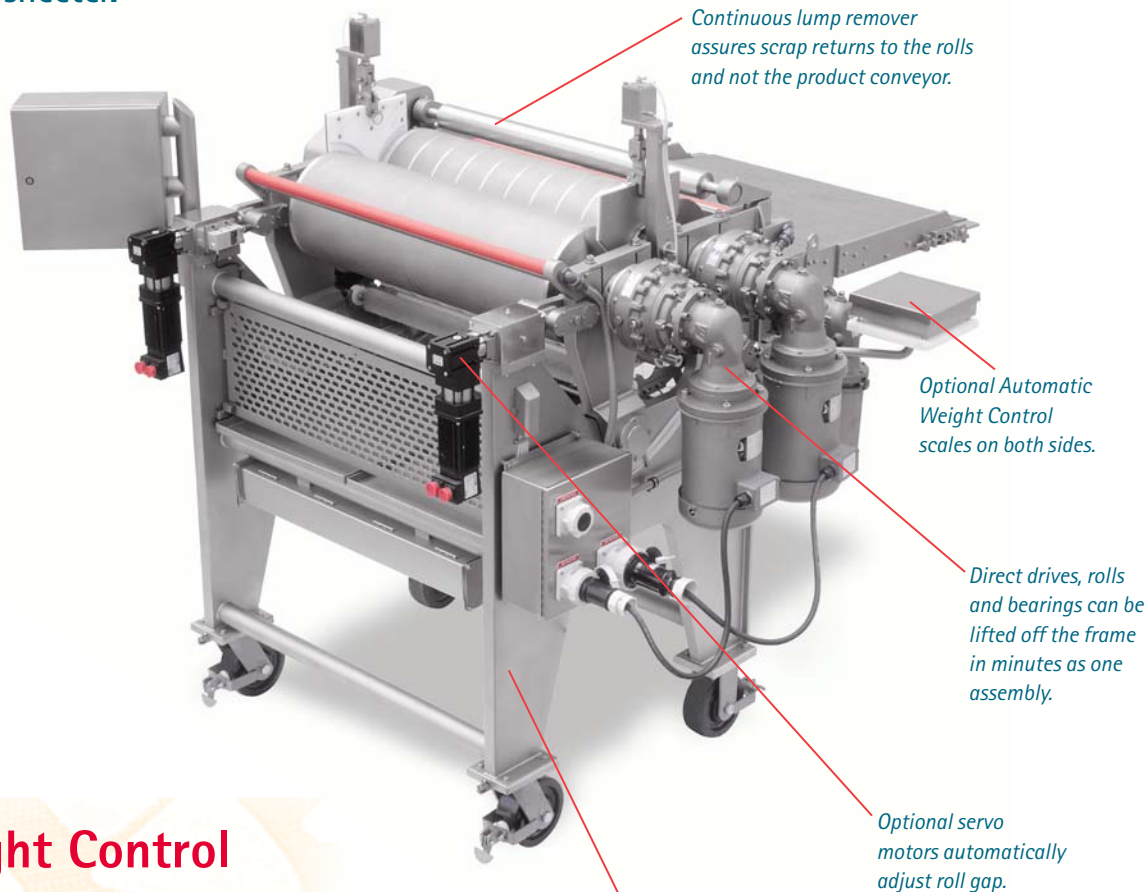

*Hinged rear roll support assures precise gap control. Retractable holder supports cutter roll during removal.*

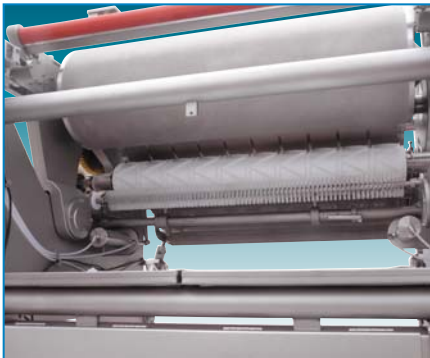

*Pneumatically controlled containment saddles prevent masa leaks. Pneumatic controls also adjust stripping wire, cutter, brush, and discharge conveyor.*



*Red tape switches stop the sheeter immediately and are easily accessible across the full width of the front and rear rolls.*

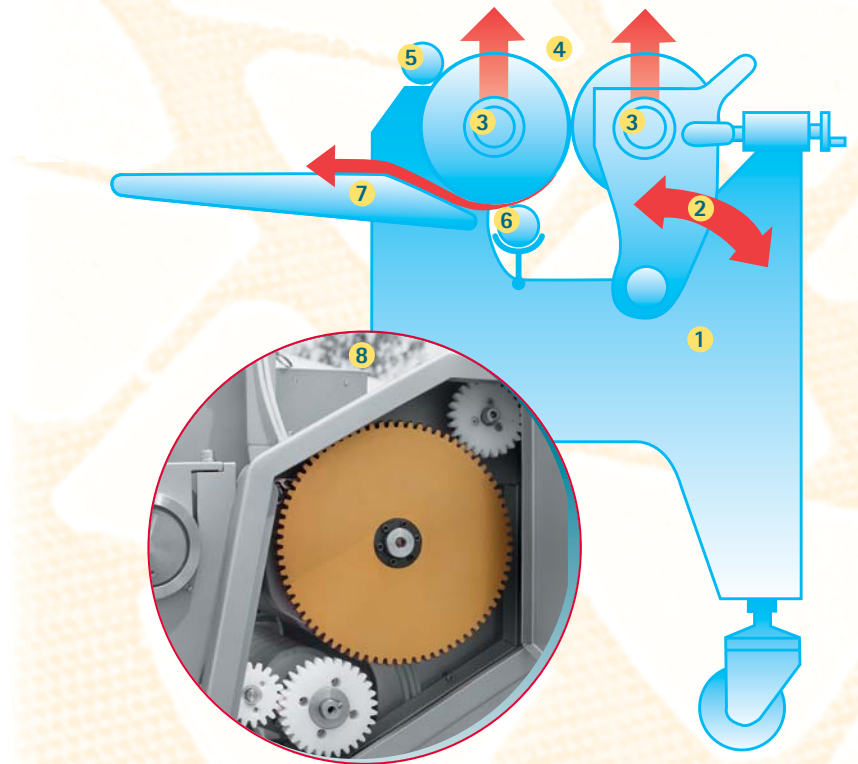
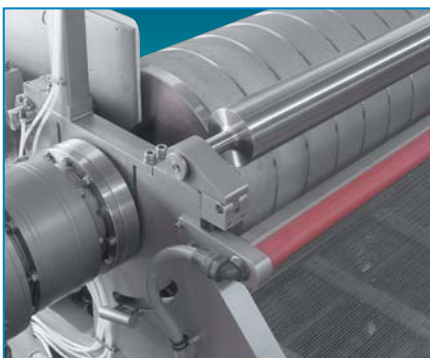

## The Paragon Difference

No other sheeter offers the robust construction and intelligent features included as standard equipment on Paragon Sheeters.

1. 1.25" to 2" thick\* stainless steel floor-length side frames eliminate product variations caused by roll deflection.
2. Hinged rear roll support pivots on bearings to maintain precise roll gap and alignment over years of service.
3. Cylindrical rolls are 12.5" to 14.5" diameter\* and 2" to 5" thick\* centrifugally cast stainless steel for maximum sheeting uniformity.
4. Rolls and drives can be replaced in minutes, instead of hours.
5. Masa lump remover prevents scrap transfer to product conveyor.
6. Cutter holder makes cutter replacement a snap and helps prevent damage.
7. Roll-contoured discharge conveyor eliminates product fold-overs and stress fractures.
8. Gear drive eliminates the maintenance required for drive belts, sprockets and chains.

*\*Depending on model*

# Paragon Sheeter | Model S

Get the most uniform product piece weight with Paragon Sheeters.

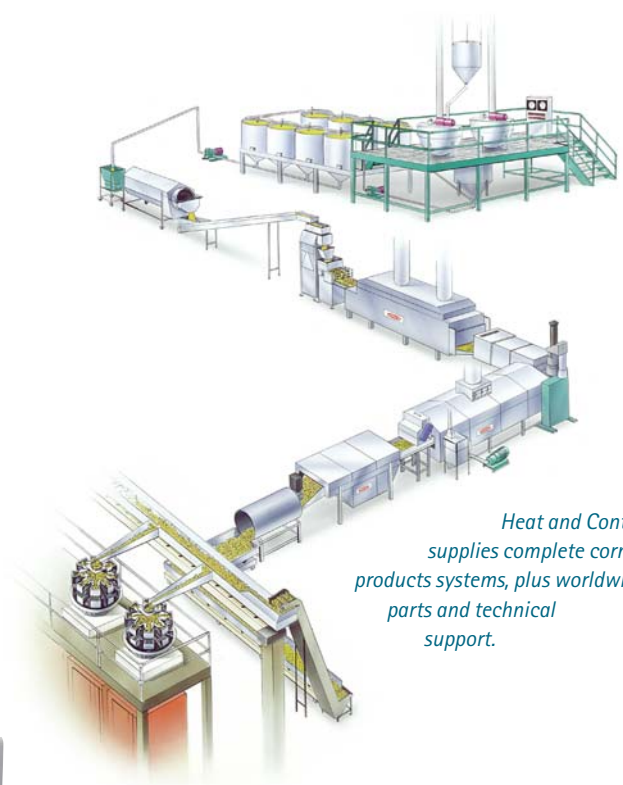

*Heat and Control supplies complete corn products systems, plus worldwide parts and technical support.*

Model	2208*	3112	3412	3912	4814
Roll Width	22.5"	31"	34"	39"	48"
Roll Diameter	8.5"	12.5"	12.5"	12.5"	14.5"
Overall Width	1143	1524	1600	1727	1956
Overall Height	32" 813	76" to 82" 1930 to 2082			

Discharge length determined by your application.

\*oven mounted 2208 sheeter

Inches | Approximate dimensions are rounded  
mm | to the nearest inch/millimeter.



Model 2208 small capacity oven-mounted Paragon Sheeters are available with portable frames.

Constant improvement and engineering innovations mean these specifications may change without notice.

**HEAT AND CONTROL**®

